

GN 416

Spring latches

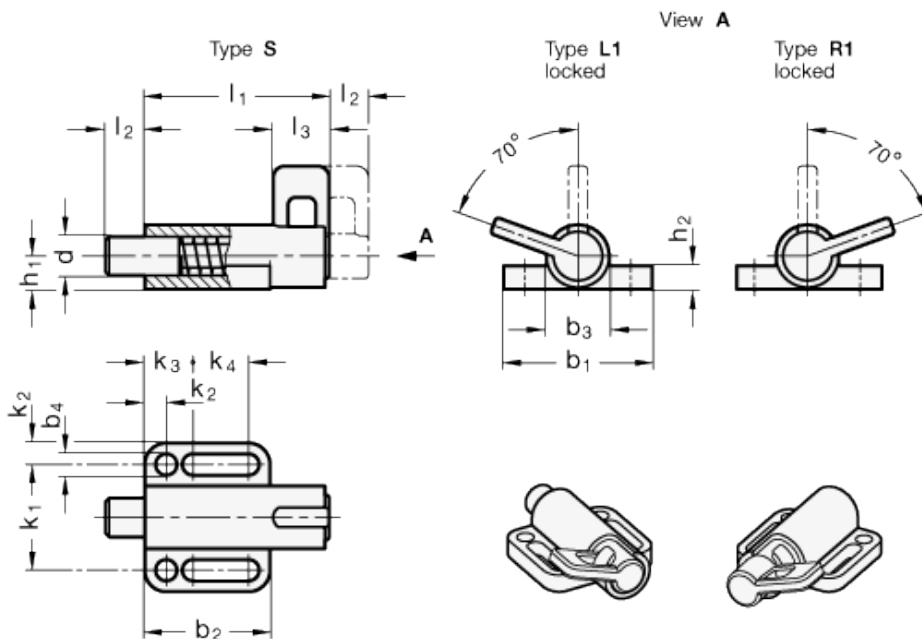

technical informations

Housing

Zinc die casting, plastic coated, RAL 9005, textured finish.

Plunger

Zinc-plated steel, blue passivated.

Spring

AISI 301 Stainless Steel.

Latch lever

Plastic Technopolymer (Polyamide PA)

- black, matte
- not removable

Standard versions available

- Type S: without locking, without rest position.
- Type L1: Locking / Rest Position via counterclockwise rotation.
- Type R1: Locking / Rest Position via clockwise rotation.

Features and applications

The plunger of spring latches GN 416 is operated by an axial pulling of the latch lever. This kind of operation from the top side is advantageous in certain installation situations. The pins of Type S spring latches are engaged in the housing to prevent rotation, and therefore lock in the starting position but not the retracted position. Types R1 and L1 spring latches offer a locking function in the starting as well as in the retracted position, preventing an unintentional operation. A lock notch holds the latch lever in both positions. The adjustment range is designed in such a way that ISO 7092 washers can be used within the adjustment slot in the housing.

Standard Elements	Main dimensions															Spring load in N \approx		Weight g
	Description	d	b ₁	b ₂	b ₃	b ₄ -0.2	h ₁	h ₂	k ₁ ±0.05	k ₂	k ₃	k ₄	l ₁	l ₂ min.	l ₃	initial	end	
GN 416-6-38-S	6	38	32	16	5.4	8.5	6	27	5.5	12	14.5	47	10	14	21	27	68	
GN 416-8-38-S	8	38	32	16	5.4	8.5	6	27	5.5	12	14.5	47	10	14	21	27	85	
GN 416-8-46-S	8	46	40	20	6.4	11	6	33	6.5	14.5	19	59	12	17	25	38	108	
GN 416-10-38-S	10	38	32	16	5.4	8.5	6	27	5.5	12	14.5	47	10	14	21	27	120	
GN 416-10-46-S	10	46	40	20	6.4	11	6	33	6.5	14.5	19	59	12	17	25	38	132	
GN 416-12-46-S	12	46	40	20	6.4	11	6	33	6.5	14.5	19	59	12	17	25	38	139	
GN 416-6-38-L1	6	38	32	16	5.4	8.5	6	27	5.5	12	14.5	47	10	14	21	27	68	
GN 416-8-38-L1	8	38	32	16	5.4	8.5	6	27	5.5	12	14.5	47	10	14	21	27	85	
GN 416-8-46-L1	8	46	40	20	6.4	11	6	33	6.5	14.5	19	59	12	17	25	38	108	
GN 416-10-38-L1	10	38	32	16	5.4	8.5	6	27	5.5	12	14.5	47	10	14	21	27	120	
GN 416-10-46-L1	10	46	40	20	6.4	11	6	33	6.5	14.5	19	59	12	17	25	38	132	
GN 416-12-46-L1	12	46	40	20	6.4	11	6	33	6.5	14.5	19	59	12	17	25	38	139	
GN 416-6-38-R1	6	38	32	16	5.4	8.5	6	27	5.5	12	14.5	47	10	14	21	27	68	
GN 416-8-38-R1	8	38	32	16	5.4	8.5	6	27	5.5	12	14.5	47	10	14	21	27	85	
GN 416-8-46-R1	8	46	40	20	6.4	11	6	33	6.5	14.5	19	59	12	17	25	38	108	
GN 416-10-38-R1	10	38	32	16	5.4	8.5	6	27	5.5	12	14.5	47	10	14	21	27	120	
GN 416-10-46-R1	10	46	40	20	6.4	11	6	33	6.5	14.5	19	59	12	17	25	38	132	
GN 416-12-46-R1	12	46	40	20	6.4	11	6	33	6.5	14.5	19	59	12	17	25	38	139	



STANDARD MACHINE ELEMENTS WORLDWIDE